



# KEPNER PRODUCTS COMPANY

ESTABLISHED IN 1948

TIPS #8 Kep-O-seal® Shuttle Valves - Functions and Applications *Page 1 of 2*

Non-biased shuttle valves are two input single output valves that are completely pressure controlled. The higher input pressure creates a pressure differential causing flow through the valve while the system pressure holds the other input port closed. The symbols shown below describe the function graphically. Shuttle valves will flow in reverse and this important characteristic distinguishes the shuttle valve from check valves placed back-to-back. In dead ended applications, such as pilot circuits and brake circuits, the system pressure must relieve when the input is removed, and the shuttle valve allows this.

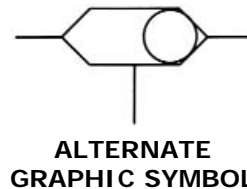
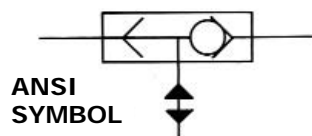

## FUNCTION

The shuttle valve is essentially an OR logic element. One input or the other provides the output used directly to do work or as a pilot by controlling a normally open or normally closed valve. The circuit shown is an OR circuit as the OR elements, (shuttle valves), are connected to a normally closed valve. Substituting a normally open valve, the circuit becomes a NOR circuit where any input stops the output. Shuttle valves are naturals for switching alternate, standby, emergency, pressure or power systems, and are essential for two input pilot control. The Kep-O-seal 2450 series are free ball shuttle valves with leak tight sealing on the closed port, short ball travel, and low pressure shifting, provide reliable shuttle performance at pressures to 3,000 psi. The following descriptions are some examples of shuttle valve applications. We hope these will generate additional ideas where shuttle valves may be the best choice for you.

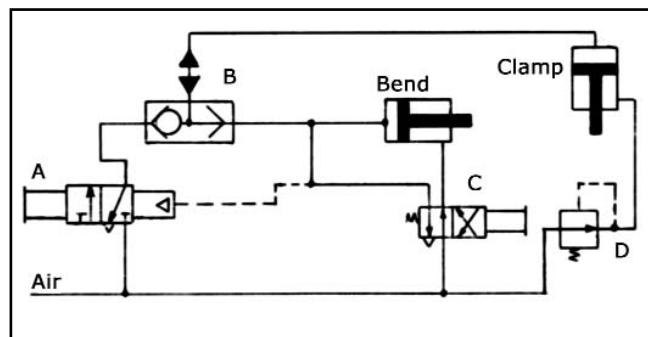
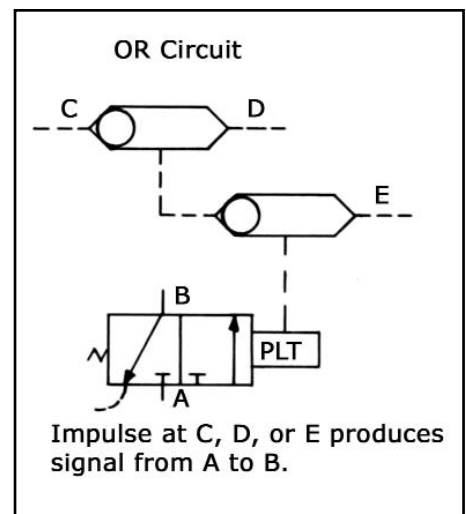

## CLAMPING AND BENDING

Valve A applies air to the up end of clamp cylinder through shuttle valve B. Operator then actuates valve C to extend the bend cylinder and reset valve A. Shuttle valve B maintains pressure in the clamp cylinder. When operator releases valve C, low pressure air from reducing valve D retracts the clamp cylinder. The pilot line of valve A is vented, and the system is ready for the next operation.

Valve performance is dependent on proper selection, application, installation and maintenance. Consult Factory.



# KEPNER PRODUCTS COMPANY

ESTABLISHED IN 1948

TIPS #8 Kep-O-seal® Shuttle Valves - Functions and Applications *Page 2 of 2*

## WINCH BRAKE CIRCUIT

The shuttle valve provides brake control in this hydraulic winch application. When the fluid motor is energized in either direction, the shuttle valve directs fluid to open the brake shoes. When the control valve is centered, the brake cylinder is vented through the shuttle valve and the brake shoes allowed to close.

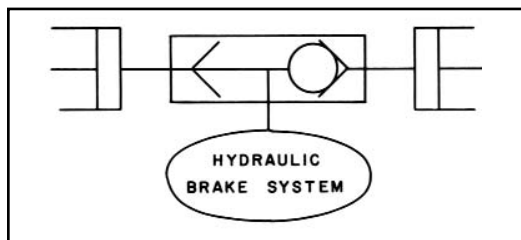
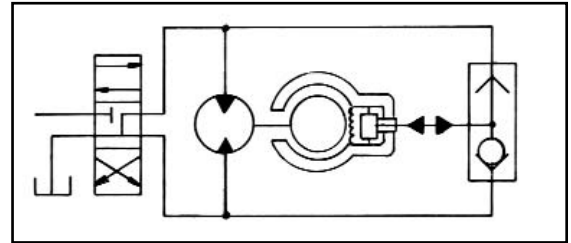

## ALTERNATE POWER INPUTS

The shuttle valve allows instant change of control from one station, or master cylinder, to the other. Many vehicles and systems are equipped with alternate control stations, or two driving stations with separate hydraulic inputs. These are directed by the shuttle valve to the required output.

## FLUID MOTOR CROSSOVER CIRCUIT

In this brake and crossover circuit the shuttle valve separates the high and low pressure legs and directs fluid to the relief valve. The shuttle valve replaces back-to-back check valves in this application.

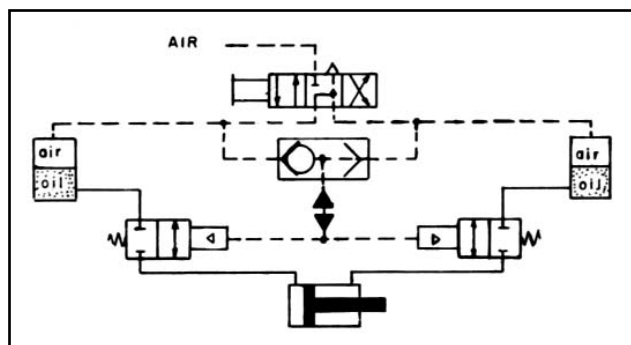
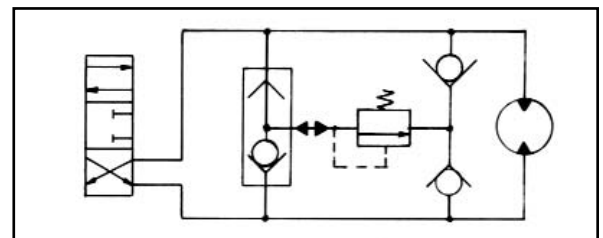

## AIR PILOT CONTROL

Converting from air to oil permits locking of the cylinder. Shifting the 4-way to either extreme position applies pilot air through the shuttle valve to hold the two air-operated valves open and apply oil under air pressure to the corresponding side of the cylinder. Positioning manual valve to neutral exhausts pilot pressure closing the 2-way valves and trapping oil on both sides of the cylinder to lock it in position.

## STANDBY AND EMERGENCY SYSTEMS

Compressor systems requiring standby or purge gas capability are pressure controlled by the shuttle valve. This would be for instrumentation, pressurize3d cables, or any system requiring continuous pneumatic input. If the compressor fails, the standby bank, (regulated to slightly under compressor supply), will shift the shuttle valve and take over the function. The shuttle valve will close the compressor inlet port preventing loss of system pressure. When compressor pressure is reestablished, the shuttle valve shifts back and seals off the standby system until needed again.

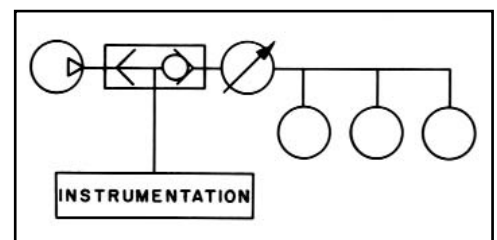

Valve performance is dependent on proper selection, application, installation and maintenance. Consult Factory.