



# KEPNER PRODUCTS COMPANY

ESTABLISHED IN 1948

TIPS #7

## Kep-O-seal® Ball Check Valves

The 400 series Kep-O-seal® Ball Check Valves have large flow paths, incorporate the Zero Leakage *Flexible Seal Seat™* and have a conical tension spring. Vibration and chatter has been eliminated and the ball checks accept most contamination and high viscosity fluids. It has been designed for general purpose oils and lubricants, hydraulic oil, air and water. Rated at 3,000 PSI operation pressure, 4,500 PSI proof pressure and 1 to 3 PSI standard crack pressure, the valve is available in brass and stainless steel with Buna-N, Teflon or Viton O-Rings.

### VISCOUS LIQUID FILLING APPLICATION

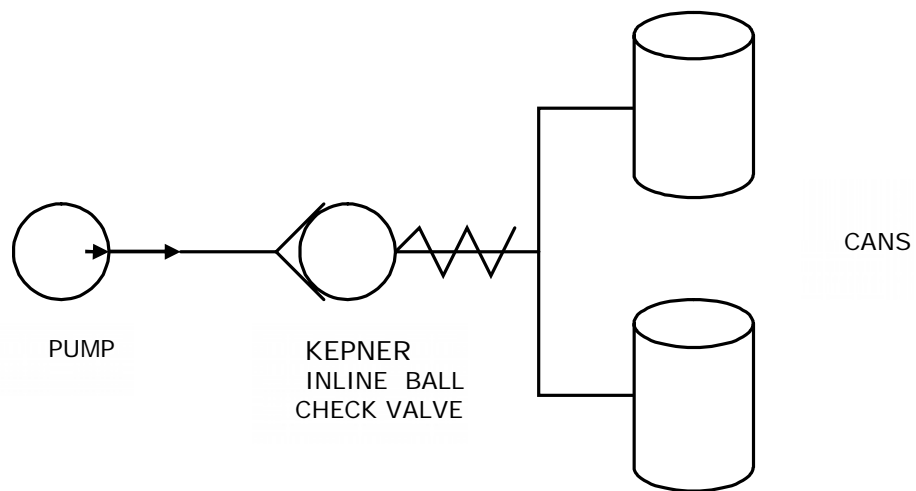

Valve performance is dependent on proper selection, application, installation and maintenance. Consult Factory.

Kepner Products Company, Villa Park, IL 630.279.1550 E-mail: [kepner@kepner.com](mailto:kepner@kepner.com)